



BS&B SAFETY SYSTEMS, L.L.C.  
BS&B SAFETY SYSTEMS, LTD.

# Installation Instructions

Bulletin 77-40031

See our website at  
[www.bsbsystems.com](http://www.bsbsystems.com) or  
[www.bsb.ie](http://www.bsb.ie) for updates.

## Types Sigma EXL™, Sigma™, SK<sub>R</sub>™, and LPS™ Rupture Disks SRB-7RS™ and S90-7R™ Safety Heads

**Warning:** Rupture disks are intended to provide a pressure relief opening. Rupture disks are designed to burst at a specified temperature and pressure, thereby relieving excess pressure or preventing excessive vacuum in a system. **IT IS IMPERATIVE THAT THESE RUPTURE DISKS BE PROPERLY INSTALLED AND SAFELY VENTED IN ORDER TO AVOID BODILY INJURY, DAMAGE TO PROPERTY, POLLUTION AND LOSS OF PRODUCT.** BS&B Safety Systems, L.L.C. and BS&B Safety Systems Ltd. supply disks selected by their customers, which are manufactured in reliance upon information and specifications supplied by the customer. BS&B Safety Systems, L.L.C. and BS&B Safety Systems Ltd. are not liable for any damage resulting from improper installation, improper system design, unsafe venting, or other factors beyond BS&B Safety Systems, L.L.C. and BS&B Safety Systems Ltd. control. Do not locate the rupture disk device where personnel, equipment or property will be exposed to released product and pressure through the disk. Handle carefully, disk and tag may have sharp edges.

### ORDER REPLACEMENT DISKS BY LOT NUMBER

(shown on disk tag).

### Before you Install a Rupture Disk

#### 1. Inspect Safety Head

Inspect safety head's mating surfaces for foreign material. Pits, dust or grit can damage the bursting disk affecting disk performance or cause leakage. If surfaces are rough, polish with a fine emery cloth. Clean if necessary. Do not machine safety head holder, dimensions are critical. The safety head size and pressure rating must match the companion pipe flange size and rating. Ensure that appropriate adjustments are made for temperature when reviewing flange rating compatibility.

#### 2. Inspect Pipe Flanges

Ensure the pipe flanges are parallel to a sufficient standard that will permit proper function of both the rupture disk device and the chosen pipe flange gaskets.

#### 3. Inspect Rupture Disk

Prior to assembly ensure that the model/type of safety head (holder) reference marked on the rupture disk tag should be checked to ensure it matches that marked on the safety head. The rupture disk burst pressure must not exceed the safety head and pipe flange rating. Handle the rupture disk carefully, holding the disk by the tag and the perimeter only.



Examine both sides of the disk checking the seating and domed surfaces for nicks, dents, scratches and foreign material, which can damage the disk, cause leakage or affect the burst pressure. Do not install a damaged disk. Installation of a damaged disk may result in premature bursting of the disk. If damaged the Sigma EXL™, Sigma™, SK<sub>R</sub>™, and LPS™ disks will open at or below their marked burst pressure. These disks use SAF™ technology (Structural Apex Forming) and a precision indentation at the center of the disk is present in all cases.

### Safety Precautions - Caution

- Only competent, trained personnel should install rupture disk safety devices in accordance with these installation instructions.

US Patent numbers: 6,178,983, 5,005,722, 5,996,605, 6,321,582, 6,446,653 and other International patents apply

## Safety Precautions - Caution

- Only competent, trained personnel should install rupture disk safety devices in accordance with these installation instructions.
- Consider recoil. Provide adequate support for piping and connections to absorb recoil/reaction forces when the disk ruptures. Recoil is the force the system will experience upon disk rupture. Recoil (lbs) is approximately twice the disk's burst pressure (psig) times the relief area (in.<sup>2</sup>). If the discharge is free vented, a baffle plate may be mounted down-stream of the outlet companion pipe flange with extra length studs to minimize recoil.
- Do not remove rupture disks from packaging for inspection until ready to install.
- The rupture disk and safety head should not be subjected to excessive structural bending stresses.
- If disks are liquid or steamed cleaned, and a high velocity particle spray or jet is used, take care not to damage the disk.
- Do not locate the disk where it may be subjected to thermal shock. Moisture, rain, condensation or snow may cause a thermal shock to the disk causing the disk to burst below its marked burst pressure. A protector is recommended for temperatures above 212°F (100°C), consult BS&B Safety Systems, L.L.C. or BS&B Safety Systems Ltd.
- Where a disk is mounted upstream of a pressure relief or safety valve, ensure that the opening of the disk does not interfere or effect the performance of the valve.
- When the disk ruptures, ensure that the opening of the disk does not affect the performance of downstream equipment. The bursting of a disk may result in a pressure shock wave.
- Do not reinstall a disk that has been removed from the piping system unless used in a pre-torqued safety head. When stresses in the disk are relieved by removing it from the safety head the disk can never resume its original installed condition, which can affect disk performance.
- Only pre-torqued safety heads (SRB-7RS™ and SRB-7FS™) with the contained rupture disk may be removed from service and re-installed provided the capscrews are not loosened, the capscrew torque is maintained and the disk is in good condition.
- The rupture disk and safety head must not be machined or modified in any way except with the approval of BS&B Safety Systems, L.L.C. or BS&B Safety Systems Ltd. Failure to obtain such approval voids the warranty on this product.
- Safety head and rupture disk materials should be compatible with your process.
- Corrosion and process conditions may deteriorate disk performance and necessitate frequent replacement.
- Warning: Should a rupture disk type RLS™, JRST™, or FRST™ and its safety head be installed upside down, the burst pressure generally exceeds 1.5 times the marked burst pressure. Should an S-90™ rupture disk and its safety head be installed upside down, the burst pressure shall not exceed 1.5 times the marked burst pressure.

### Installation of Rupture Disk in SRB-7RS™ Safety Head (Refer to Figure 2)

1. Place inlet of Safety Head on a flat work surface in position as shown in (Figure 1) with **flow arrows and locating pins up**.
2. Place NEW, UNDAMAGED rupture disk on inlet so locating pins mate with the corresponding holes in the rupture disk.
3. Carefully align and place outlet flange in position as shown. **Ensure flow arrows on the disk tag and on the Safety Head point in the same direction.**
4. Assemble unit with recessed capscrews. Tighten all 12-point high strength capscrews with socket (See Table I for socket type) finger tight before torquing. **DO NOT SUBSTITUTE** for capscrews supplied. Do not lubricate blue fluoropolymer coated capscrews.
5. Evenly torque the capscrews to the value shown in Table I when using uncoated capscrews or Table II when using blue color fluoropolymer coated capscrews. Torque evenly in a diagonal pattern by applying 1/4 of the torque value to capscrew (1), and then applying torque to (2), (3) and (4) etc. Repeat the torquing pattern for 1/2 then 3/4 of the recommended torque value. Finally using same pattern, torque to full torque value.
6. The 12-point capscrew heads should be recessed into the SRB-7RS Safety Head outlet after installation.
7. Sizes 2" (50mm) and above have a "bite-type" seal on the SRB-7RS inlet face that engages with the rupture disk. Do not modify this feature in any way. Should the 'bite-type' seal be incomplete or damaged contact BS&B Safety Systems, Inc. or BS&B Safety Systems Ltd. for repair.

Note: Uneven or undertorquing can cause disk rupture below its marked burst pressure. Excessive torquing can cause damage to the disk and Safety Head.

## Installation of Safety Head SRB-7RS™ Assembly in Pressure System (Refer to Figure 3)

1. Insert the Safety Head assembly into the pressure system between companion flanges. *Ensure flow arrows on the Safety Head and disk tag point in the desired flow direction upon disk rupture.* The SRB-7RS™ nestles inside the bolting pattern of pipe flanges and the J-Bolt prevents the Safety Head from being installed incorrectly with respect to flow. The inlet companion flange must be radially drilled to accept the J-Bolt. Table IV lists companion flange drilling dimensions.
  2. Install gaskets between the Safety Head and the companion flanges. We recommend a compressed fiber gasket no greater than 1/16" (1.6mm) thick for this application. However, the user is cautioned to select gasket materials adequate for the service conditions and the ability of the gasket to resist "cold flow". Gaskets that cold flow will allow torque relaxation in non-pretorqueable Safety Heads which may cause low bursts. (The rupture pressure of disks installed in pretorqueable safety heads SRB-7RS™ are unaffected.)
  3. Install studs and nuts. Studs with nuts should be free running with lightly oiled threads, see table V for stud details. Tighten all nuts finger tight. Torque the nuts to the value shown in Table III. **Torque evenly in a diagonal pattern** by applying 1/4 of the recommended torque to each stud. Repeat pattern by torquing to 3/4 of the recommended torque value. Then using same pattern torque to full torque value. Do not exceed the specified torque value.
  4. The torque value on the companion flange nuts should be verified periodically at the system service temperature.
- Warning:** Should the device be installed upside down, the burst pressure generally exceeds 1.5 times the marked burst pressure.

**Figure 1: Inlet Companion Flange Drilling to Accept J-Bolt**

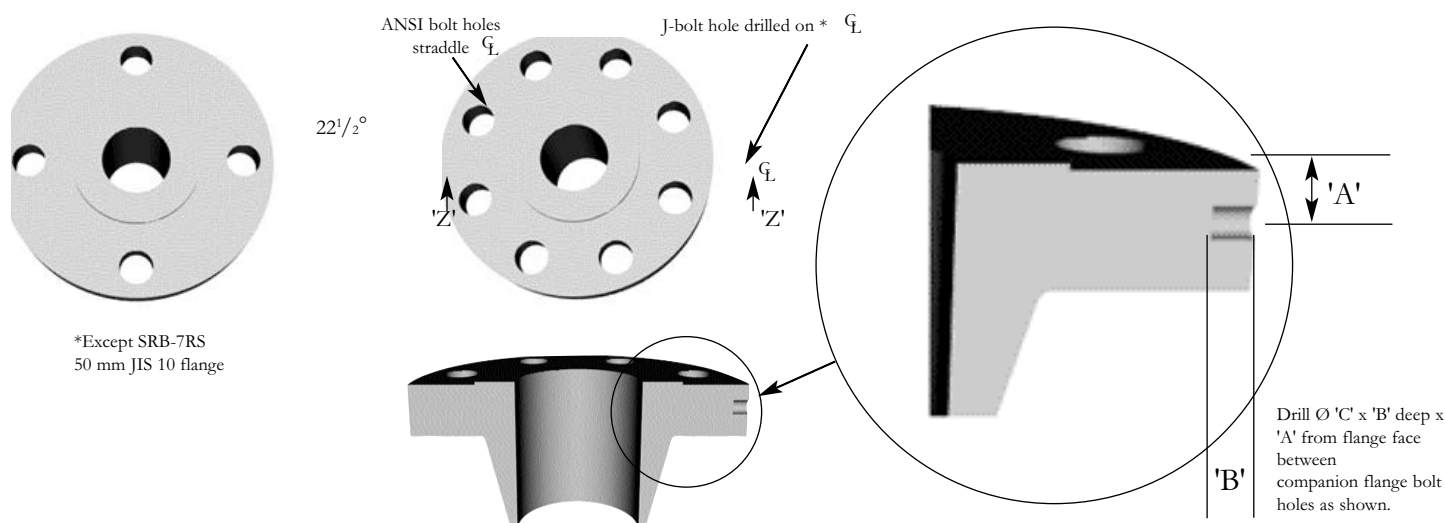

### J-Bolt Drilling

The SRB-7RS™ (See Fig 3) and S90-7R™ fit inside the bolting pattern of the companion flange. See appropriate figure for your assembly. The J-Bolt prevents the Safety Head from being installed upside down. The inlet companion flange must be drilled to accept the J-Bolt. See table IV.

Figure 2  
Safety Head Type SRB-7RS™

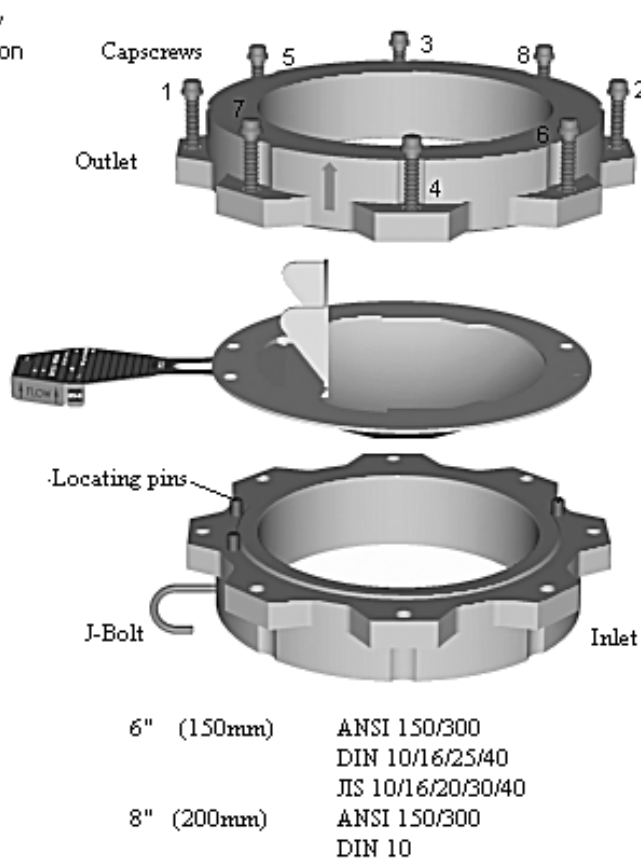
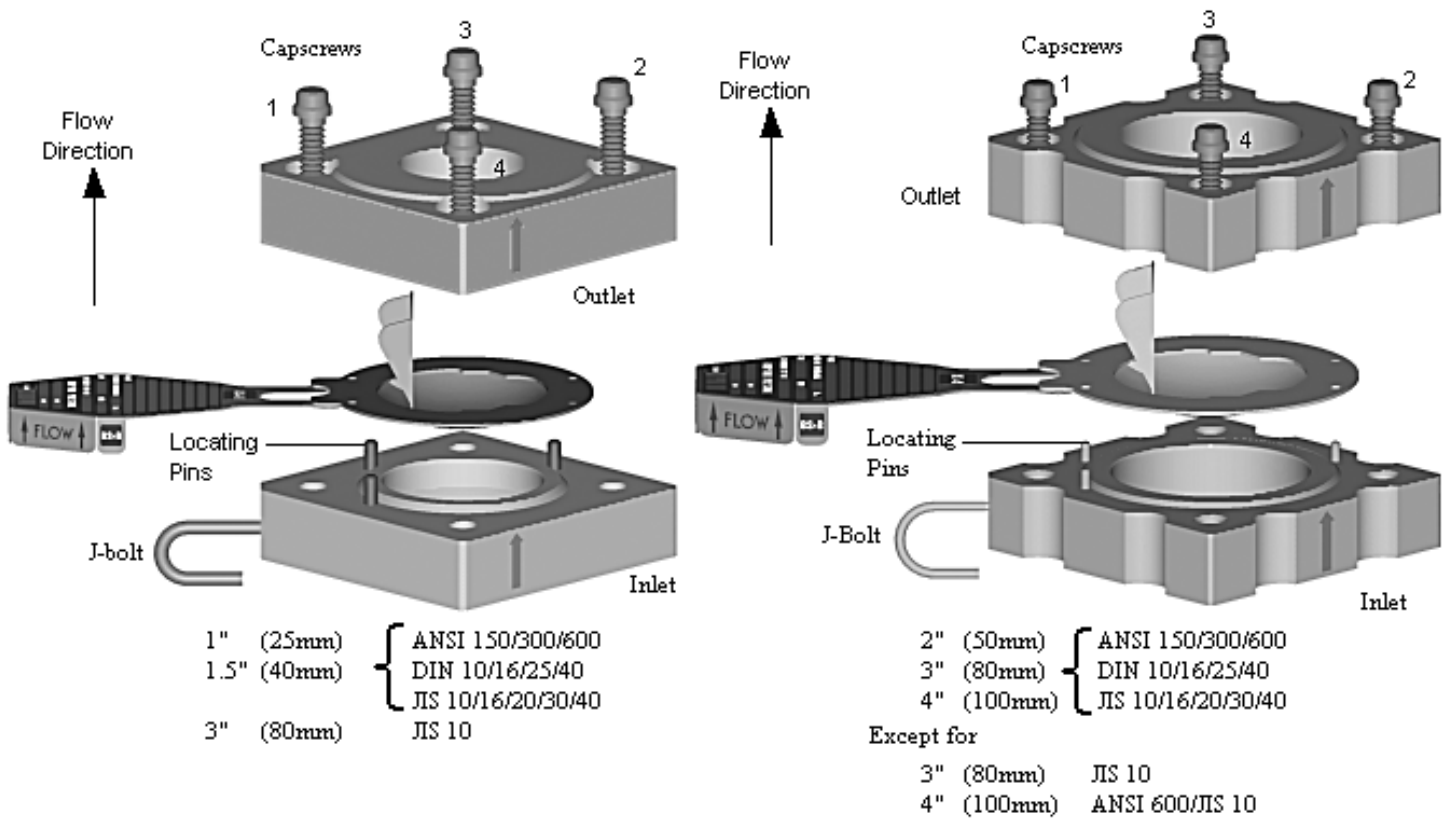

**Table I: SRB-7RS™ Preassembly Capscrew Torque using uncoated capscrews**

SIZE		SAFETY HEAD FLANGE RATING			PREASSEMBLY CAP-SCREW TORQUE		12 POINT SOCKET SIZE	SOCKET DRIVE*	SUGGESTED SOCKET SOURCE SNAP-ON TOOLS
IN	MM	ANSI	DIN	JIS	FT-LB	NT-M	IN	IN	
1	25	150			10	14	1/4	1/4	STMD-8
1	25	300/600	10/16/25/40	10/16/20/30/40	10	14	1/4	1/4	STMD-8
1.5	40	150		10/16/20	13	18	5/16	1/4	STMD-10
1.5	40	300/600	10/16/25/40	30/40	13	18	5/16	1/4	STMD-10
2	50	150	10/16/25/40	10	22	30	5/16	1/4	STMD-10
2	50	300/600		16/20/30/40	22	30	5/16	1/4	STMD-10
3	80	150	10/16	16	26	35	3/8	3/8*	SF-121
3	80	300/600	25/40	20/30/40	26	35	3/8	3/8*	SF-121
4	100	150	10/16	10/16	55	75	7/16	3/8*	SF-141
4	100	300	25/40	20/30/40	55	75	7/16	3/8*	SF-141
6	150	150	10/16	10	36	50	3/8	3/8*	SF-121
6	150	300	25/40	30	36	50	3/8	3/8*	SF-121
8	200	150	10/16	10/16/20	45	62	7/16	3/8*	SF-141
8	200	300			45	62	7/16	3/8*	SF-141
10	250	150/300	10/16	10/16	34	46	7/16	3/8*	SF-141

Notes: \* 12 point, deep length, thin wall socket

The torque values in the table above are based on the assumption of lightly oiled, clean free running threads with a co-efficient of friction of  $\mu = 0.16$ . The customer is advised that the effects of corrosion, the use of particular thread compounds or dry assembly, may result in a change in the effective clamp load on the disk assembly. This may adversely affect the performance of the bursting disk device.

**Table II: SRB-7RS™ Preassembly Capscrew Torque using blue fluoropolymer coated capscrews  
MAX. Temperature 260°C (500°F)**

SIZE		SAFETY HEAD FLANGE RATING			PREASSEMBLY CAP-SCREW TORQUE		12 POINT SOCKET SIZE	SOCKET DRIVE*	SUGGESTED SOCKET SOURCE SNAP-ON TOOLS
IN	MM	ANSI	DIN	JIS	FT-LB	NT-M	IN	IN	
1	25	150			5	7	1/4	1/4	STMD-8
1	25	300/600	10/16/25/40	10/16/20/30/40	5	7	1/4	1/4	STMD-8
1.5	40	150		10/16/20	7	9	5/16	1/4	STMD-10
1.5	40	300/600	10/16/25/40	30/40	7	9	5/16	1/4	STMD-10
2	50	150	10/16/25/40	10	11	15	5/16	1/4	STMD-10
2	50	300/600		16/20/30/40	11	15	5/16	1/4	STMD-10
3	80	150	10/16	16	13	18	3/8	3/8*	SF-121
3	80	300/600	25/40	20/30/40	13	18	3/8	3/8*	SF-121
4	100	150	10/16	10/16	28	38	7/16	3/8*	SF-141
4	100	300	25/40	20/30/40	28	38	7/16	3/8*	SF-141
6	150	150	10/16	10	18	25	3/8	3/8*	SF-121
6	150	300	25/40	30	18	25	3/8	3/8*	SF-121
8	200	150	10/16	10/16/20	23	31	7/16	3/8*	SF-141
8	200	300			23	31	7/16	3/8*	SF-141
10	250	150/300	10/16	10/16	17	23	7/16	3/8*	SF-141

Notes: \* 12 point, deep length, thin wall socket

Do not use thread lubricant with blue fluoropolymer coated capscrews

**Table III: SRB-7RS™ for SK<sub>R</sub>™ SIGMA EXL™, SIGMA™, and LPS™  
and S90-7R (for SK<sub>R</sub>™ disk only) Companion Flange Torque**

SIZE		COMPANION FLANGE RATING			COMPANION FLANGE TORQUE	
IN	MM	ANSI	DIN	JIS	FT-LB	NT-M
1	25	150	10/16	-	20	27
1	25	-	-	10/16/20	25	34
1	25	-	25/40	-	20	27
1	25	300/600	-	-	40	54
1	25	-	-	30/40	25	34
1.5	40	150	-	-	25	34
1.5	40	-	10/16	10/16/20	32	44
1.5	40	300/600	-	-	60	80
1.5	40	-	25/40	-	32	44
1.5	40	-	-	30/40	60	80
2	50	150	-	-	52	70
2	50	-	10/16	10	52	70
2	50	-	25/40	-	52	70
2	50	300/600	-	-	35	47
2	50	-	-	16/20/30/40	35	47
3	80	150	-	-	55	75
3	80	-	10/16	10	48	65
3	80	-	25/40	-	48	65
3	80	300/600	-	-	62	84
3	80	-	-	16/20/30/40	62	84
4	100	150	-	-	44	60
4	100	-	10/16	10	44	60
4	100	300	25/40	16/20	70	95
4	100	-	-	30/40	81	110
6	150	150	10/16	10	74	100
6	150	-	-	16/20	87	118
6	150	300	-	-	74	100
6	150	-	25/40	30	95	130
8	200	150	10	-	78	106
8	200	-	16	-	68	92
8	200	300	-	-	128	174
8	200	-	-	10/16	87	118
8	200	-	-	20	115	155
10	250	150	-	-	103	139
10	250	300	-	-	172	233
10	250	-	10	10	82	111
10	250	-	16	16	110	149

Torque values are based on the use of compressed fiber gaskets.

The above torque values are suitable for use with studs of a minimum design stress of 25,000 psi as defined in ASME Section II Table III. The companion flanges must be compatible for use with stud stresses up to 25,000 psi. Consult BS&B Safety Systems, L.L.C. or BS&B Safety Systems Ltd. for flanges in other materials, when suppliers recommend torque values lower than the BS&B Safety Systems, L.L.C. or BS&B Safety Systems Ltd. recommended torque values and if gasket type differs from BS&B Safety Systems, L.L.C. or BS&B Safety Systems Ltd. recommendations.

The torque values in the table above are based on the assumption of lightly oiled, clean free running threads with a co-efficient of friction of  $\mu = 0.16$ . The customer is advised that the effects of corrosion, the use of particular thread compounds or dry assembly, may result in a change in the effective clamp load on the disk assembly. This may adversely affect the performance of the bursting disk device.

**Figure 3**  
**SRB-7RS™ Safety Heads Inside the Flange Bolting Pattern**



1" (25 mm)      ANSI 150/300/600  
 DIN 10/16/25/40  
 JIS 10/16/20/30/40  
 1.5" (40mm)    ANSI 150/300/600  
 DIN 10/16/25/40  
 JIS 10/16/20/30/40



2" (50mm)      ANSI 150  
 JIS 10

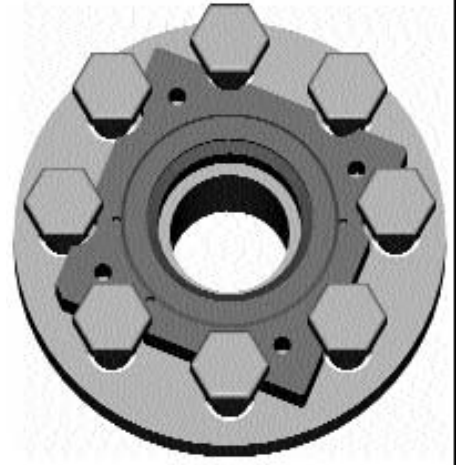

2" (50mm)      ANSI 300/600  
 JIS 16/20/30/40  
 3" (DN80)      ANSI 300/600  
 DIN 10/16/25/40  
 JIS 16/20/30/40  
 4" (DN100)     ANSI 150/300  
 DIN 10/16/25/40  
 JIS 10/16/20/30/40



2" (50mm)      ANSI 150  
 DIN 10/16/25/40  
 3" (80mm)      ANSI 150



3" (80mm)      JIS 10



6" (150mm)     ANSI 150  
 DIN 10/16/25/40  
 JIS 10  
 8" (200mm)     ANSI 150  
 DIN 10



6" (150mm)     ANSI 300  
 JIS 30/40  
 8" (200mm)     ANSI 300  
 10" (250mm)    ANSI 150

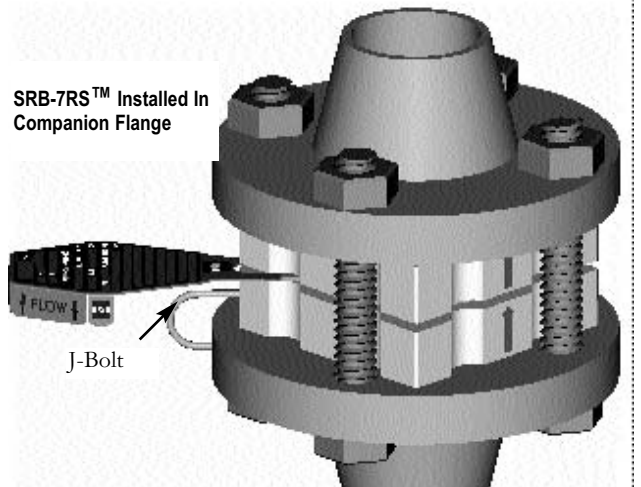

## Installation of Rupture Disk in a Quik-Sert S90-7R™ Safety Head

Not for disk types Sigma EXL™, Sigma™, and LPS

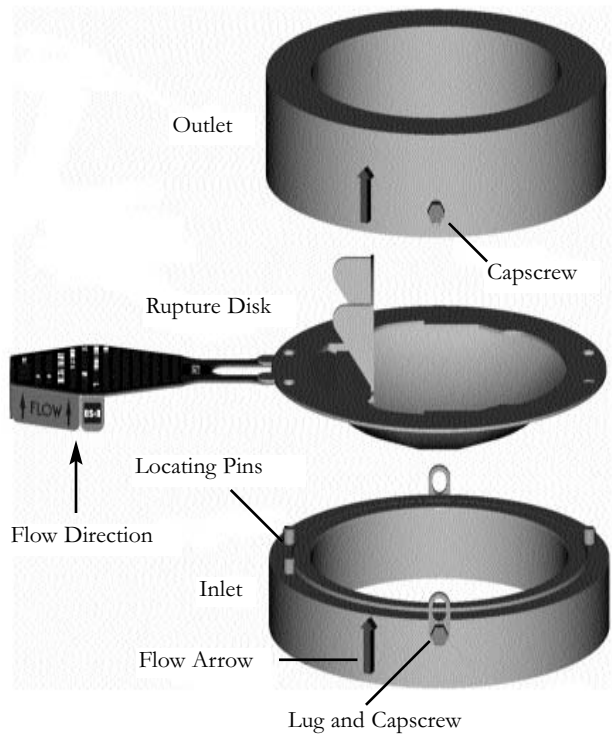

### Type S90-7R™ Safety Head

Not for disk types Sigma EXL™, Sigma™, and LPS

1. Place inlet of Safety Head on a work surface in position shown in diagram with **flow arrows and locating pins up**.
2. Place NEW, UNDAMAGED rupture disk on inlet flange so locating pins mate with the corresponding holes in the rupture disk. Flow arrows on disk tag should indicate direction of flow.
3. Carefully align and place outlet flange in position as shown. **Ensure flow arrows on the disk tag and on the Safety Head point in the same direction.**
4. Assemble unit with alignment lugs and capscrews. Tighten capscrews only sufficiently to hold disk snugly in place between the two flanges.
5. Sizes 2" (50mm) and above have a 'bite-type' seal on the inlet face that engages with the rupture disk. Do not modify this feature in any way. Should the 'bite-type' seal be incomplete or damaged, contact BS&B for repair

## Installation of Safety Head S90-7R™ Assembly in Pressure System

1. Insert Safety Head assembly into pressure system between companion pipe flanges. **Ensure flow arrows on disk tag and Safety Head point in desired flow direction upon disk rupture.**
2. Install gaskets between S90-7R™ Safety Head and mating pipe flanges. A hard compressed fiber gasket no greater than 1/16" (1.6mm) thick is recommended. However, the user is cautioned to select gasket materials adequate for the service conditions and the ability of the gasket to resist "cold flow". Gaskets that "cold flow" will allow torque relaxation which will cause low bursts. **Contact BS&B Safety Systems, L.L.C. or BS&B Safety Systems Ltd if an alternative gasket type is used, or for advice on the use of spiral wound gaskets.**
3. Install studs with nuts which should be free-running with lightly oiled threads. Tighten all nuts finger tight. Torque the nuts to value shown in Table III. **Torque evenly in a diagonal pattern** by applying 1/4 of recommended torque to each stud. Repeat pattern by torquing to 3/4 of recommended torque value. Then using same pattern torque to full specified torque value. Do not exceed the specified torque value.
4. The torque value on the companion flange nuts should be verified periodically at the system service temperature.

**Note:** Uneven or undertorquing can cause disk rupture below its marked burst pressure. Excessive torquing can damage the disk and Safety Head.

**Note:** All torque values are for compressed fiber gaskets.

**Warning:** Should the device be installed upside down, the burst pressure generally exceeds 1.5 times the marked burst pressure.

### S90-7R™ INSTALLED BETWEEN COMPANION PIPE FLANGE

The S90-7R™ nestles inside the bolting pattern of pipe flanges.

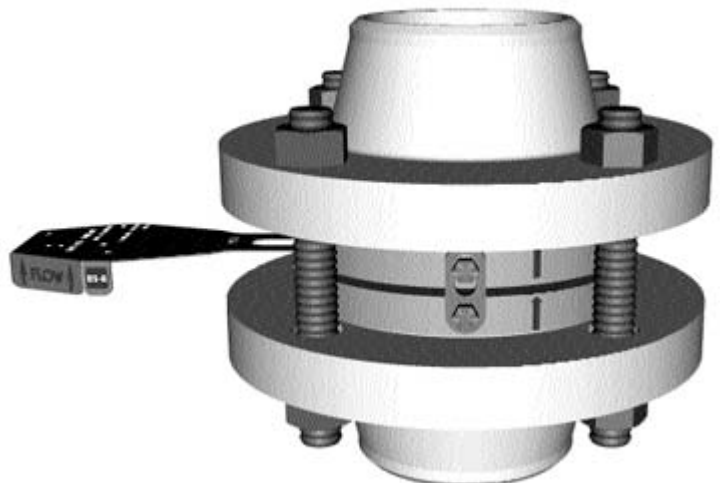



**Table IV**  
**SRB-7RS™ Safety Head Companion Flange J-Bolt Drilling Dimensions**

SIZE		COMPANION FLANGE RATING			DIMENSIONS					
					A		B		C	
IN	MM	ANSI	DIN	JIS	IN +/- 1/32	MM +/- .8	IN +1/16 -0	MM +1.6 -0	IN	MM
1	25	150	-	-	5/16	8	7/16	11	3/8	9.5
1	25	-	10/16	-	13/32	10	5/16	8	7/16	11
1	25	-	-	10/16	9/32	7	35/64	14	7/16	11
1	25	300	-	-	7/16	11	1/2	13	3/8	9.5
1	25	-	25	-	13/32	10	5/16	8	7/16	11
1	25	-	-	20	9/32	7	5/8	16	7/16	11
1	25	600	-	-	1/2	13	5/8	16	3/8	9.5
1	25	-	40	-	13/32	10	35/64	14	7/16	11
1	25	-	-	30/40	13/32	10	6/8	16	7/16	11
1.5	40	150	-	-	3/8	9.5	7/16	11	7/16	11
1.5	40	-	10/16	-	13/32	10	13/32	10	7/16	11
1.5	40	-	-	10/16/2020	11/32	9	5/8	16	7/16	11
1.5	40	300	-	-	1/2	13	1/2	13	7/16	11
1.5	40	-	25/40	-	13/32	10	13/32	10	7/16	11
1.5	40	-	-	30/40	7/16	11	19/32	15	7/16	11
1.5	40	600	-	-	9/16	14.5	1/2	13	7/16	11
2	50	150	-	-	7/16	11	7/16	11	7/16	11
2	50	-	-	10/16/2020	13/32	10	7/16	11	7/16	11
2	50	-	10/16/25/40	-	15/32	12	19/32	15	7/16	11
2	50	-	-	30/40	15/32	12	5/8	16	7/16	11
2	50	300/600	-	-	9/16	14.5	11/16	17.5	7/16	11
3	80	150	-	-	5/8	16	7/16	11	7/16	11
3	80	-	-	10	13/32	10	13/32	10	7/16	11
3	80	-	10/16/25/40	-	15/32	12	13/32	10	1/2	13
3	80	-	-	16/20	1/2	13	11/32	9	7/16	11
3	80	300/600	-	-	5/8	16	13/16	20.5	7/16	11
3	80	-	-	30/40	1/2	13	19/32	15	7/16	11
4	100	150	-	-	5/8	16	9/16	14.5	7/16	11
4	100	-	10/16	-	15/32	12	13/32	10	19/32	15
4	100	-	-	10	13/32	10	13/32	10	7/16	11
4	100	300	-	-	5/8	16	1-1/6	27	7/16	11
4	100	-	25/40	-	15/32	12	23/32	18	19/32	15
4	100	-	-	16/20	19/32	15	1/2	13	7/16	11
4	100	600	-	-	13/16	20.5	9/16	14.5	7/16	11
4	100	-	-	30	19/32	15	25/32	20	7/16	11
4	100	-	-	40	19/32	15	1-1/32	26	7/16	11
6	150	150	-	-	5/8	16	9/16	14.5	7/16	11
6	150	-	10/16	-	15/32	12	7/16	11	5/8	16
6	150	-	-	10	35/64	14	5/16	8	7/16	11
6	150	-	-	16/20	13/32	10	15/32	12	7/16	11
6	150	300	-	-	11/16	17.5	1-5/16	33.5	7/16	11
6	150	-	25/40	-	15/32	12	3/4	19	5/8	16
6	150	600	-	-	13/16	20.5	9/16	14.5	7/16	11
6	150	-	-	30	43/64	17	1-3/16	30	7/16	11
6	150	-	-	40	43/64	17	1-49/64	45	7/16	11
8	200	150	-	-	5/8	16	1/2	13	5/8	16
8	200	300	-	-	5/8	16	1-1/4	32	5/8	16
10	250	150	-	-	5/8	16	1/2	13	5/8	16
10	250	300	-	-	5/8	16	1-1/4	32	5/8	16

**Table V**  
**SRB-7RS™ Safety Head Companion Flange Studs**

SIZE		COMPANION FLANGE RATING			Number of Studs	DIAMETER OF STUD		MINIMUM LENGTH OF STUD	
IN	MM	ANSI	DIN	JIS		IN	MM	IN	MM
1	25	150	-	-	4	1/2	-	4-1/2	-
1	25	300	-	-	4	5/8	-	5-1/2	-
1	25	600	-	-	4	5/8	-	5-1/2	-
1	25	900/1500	-	-	4	5/8	-	8-1/2	-
1	25	-	10/16/25/40	-	4	-	12	-	125
1	25	-	-	10/16/20	4	-	16	-	135
1	25	-	-	30/40	4	-	16	-	135
1.5	40	150	-	-	4	1/2	-	5	-
1.5	40	300/600	-	-	4	3/4	-	6-1/2	-
1.5	40	900/1500	-	-	4	1	-	8-1/2	-
1.5	40	-	10/16/25/40	-	4	-	16	-	135
1.5	40	-	-	10/16/20	4	-	16	-	140
1.5	40	-	-	30/40	4	-	20	-	150
2	50	150	-	-	4	5/8	-	6-1/2	-
2	50	300	-	-	8	5/8	-	6-1/2	-
2	50	600	-	-	8	5/8	-	6-1/2	-
2	50	900/1500	-	-	8	5/8	-	9-1/2	-
2	50	-	10/16/25/40	-	4	-	16	-	145
2	50	-	-	10	4	-	16	-	140
2	50	-	-	16/20	8	-	16	-	140
2	50	-	-	30/40	8	-	16	-	155
3	80	150	-	-	4	5/8	-	6-1/2	-
3	80	300	-	-	8	3/4	-	7-1/2	-
3	80	600	-	-	8	3/4	-	7-1/2	-
3	80	900	-	-	8	5/8	-	10	-
3	80	1500	-	-	8	1-1/8	-	12-1/2	-
3	80	-	10	-	8	-	16	-	155
3	80	-	16/25/40	-	8	-	16	-	160
3	80	-	-	10	8	-	16	-	155
3	80	-	-	16/20	8	-	20	-	165
3	80	-	-	30/40	8	-	20	-	185
4	100	150	-	-	8	5/8	-	7-1/2	-
4	100	300	-	-	8	3/4	-	8-1/2	-
4	100	600	-	-	8	7/8	-	8	-
4	100	-	10/16	10	8	-	16	-	180
4	100	-	25/40	-	8	-	21	-	185
4	100	-	-	16/20	8	-	20	-	195
4	100	-	-	30/40	8	-	22	-	210
6	150	150	-	-	8	3/4	-	8-3/4	-
6	150	300	-	-	12	3/4	-	9-1/2	-
6	150	600	-	-	12	1	-	10-1/2	-
6	150	-	10/16	-	8	-	21	-	205
6	150	-	25/40	-	8	-	25	-	225
6	150	-	-	10	8	-	20	-	205
6	150	-	-	16/20	12	-	22	-	235
6	150	-	-	30	12	-	24	-	245
6	150	-	-	40	12	-	30	-	270
8	200	150	-	-	8	3/4	-	9	-
8	200	300	-	-	12	7/8	-	10	-
10	250	150	-	-	12	7/8	-	9-1/2	-
10	250	300	-	-	16	1	-	11	-

For other safety head types, consult BS&B Safety Systems, Inc. or BS&B Safety Systems Ltd. This data assumes the use of a standard specification SRB-7RS Safety Head as indicated in Catalog 77-4001

**Limitations of Warranties** – BS&B Safety Systems, L.L.C. and BS&B Safety Systems Ltd. warrants their products, when properly installed, used and maintained by the original purchaser, against defective workmanship and materials for a period of twelve (12) months from the date of shipment. Purchaser's failure to use this product in strict compliance with all material operating specifications provided to BS&B Safety Systems, L.L.C. or BS&B Safety Systems Ltd. by purchaser prior to BS&B Safety Systems, L.L.C. or BS&B Safety Systems Ltd. production or shipment of this product shall void this warranty. Rupture disks are warranted solely to burst within specified pressure ranges at temperatures specified at the time of sale.

Where pressure relief or other products used by Buyer involve multi-part assemblies, each part must be manufactured by BS&B Safety Systems, L.L.C. or BS&B Safety Systems Ltd. BS&B Safety Systems, L.L.C. and BS&B Safety Systems Ltd. specifically disclaim any warranties and any and all liability for damages, either direct or indirect, incidental or consequential, arising from the use of rupture disk assemblies (e.g. rupture disk and rupture disk holder), explosion vent assemblies (e.g. vent and safety frame) or other assemblies not wholly comprised of BS&B Safety Systems, L.L.C. and BS&B Safety Systems Ltd. manufactured products.

BS&B Safety Systems, L.L.C. and BS&B Safety Systems Ltd. do not warrant any article not manufactured by BS&B Safety Systems, L.L.C. or BS&B Safety Systems Ltd. BS&B Safety Systems, L.L.C. and BS&B Safety Systems Ltd. do not warrant this product against loss or damage caused directly or indirectly by improper pressure relief system design; by the improper use, maintenance or installation (including improper torque) of this product; or by corrosion erosion or malfunction caused by acids, chemicals, fumes, rust, dirt, debris, thermal shock, shock waves or other external agencies over which BS&B Safety Systems, L.L.C. and BS&B Safety Systems Ltd. have no control.

THE EXPRESSED WARRANTIES HEREIN GIVEN ARE EXCLUSIVE AND IN LIEU OF ALL WARRANTIES EXPRESSED OR IMPLIED, BY OPERATION OF LAW OR OTHERWISE, INCLUDING, WITHOUT LIMITATION, ANY IMPLIED WARRANTY OF MERCHANTABILITY OR FITNESS FOR A PARTICULAR PURPOSE. BUYER'S SOLE AND EXCLUSIVE REMEDY FOR BREACH OF ANY WARRANTY SHALL BE, AT BS&B Safety Systems, L.L.C. OR BS&B SAFETY SYSTEMS LTD. OPTION, THE REPAIR OR REPLACEMENT OF THE PRODUCT, F.O.B. TULSA, OKLAHOMA, OR LIMERICK, IRELAND.

**Liability Limitations** – BS&B Safety Systems, L.L.C. and BS&B Safety Systems Ltd. manufacture and supply their products in reliance upon information and specifications provided by its customers. BS&B Safety Systems, L.L.C. and BS&B Safety Systems Ltd. specifically disclaim any and all liability, of whatever nature, resulting or arising from Buyer's failure to disclose fully all material operating conditions, design parameters, process components, or system or vessel requirements, or from any misrepresentations or omissions by Buyer, Buyer agrees to indemnify and hold harmless BS&B Safety Systems, L.L.C. or BS&B Safety Systems Ltd. for all costs, loss, liability or damage arising or resulting from BS&B Safety Systems, L.L.C. or BS&B Safety Systems Ltd. manufacture or supply of this product in accordance with Buyer's specifications or requirements.

BS&B Safety Systems, L.L.C. OR BS&B SAFETY SYSTEMS LTD. AGGREGATE TOTAL LIABILITY TO BUYER FOR ANY AND ALL LOSS OR DAMAGE ARISING OUT OF BUYER'S USE OF, OR INABILITY TO USE, THE PRODUCT SHALL IN NO EVENT EXCEED THE PURCHASE PRICE OF THE PRODUCT OR \$1,000.00, WHICHEVER IS LESSER, BS&B Safety Systems, L.L.C. OR BS&B SAFETY SYSTEMS LTD. SHALL NOT BE LIABLE FOR PERSONAL INJURY OR PROPERTY DAMAGE ARISING OUT OF BUYER'S PURCHASE, INSTALLATION OR USE OF THE PRODUCT, AND IN NO EVENT SHALL BS&B Safety Systems, L.L.C. OR BS&B SAFETY SYSTEMS LTD. BE LIABLE FOR SPECIAL, INCIDENTAL, CONSEQUENTIAL OR PUNITIVE DAMAGES RESULTING FROM ANY SUCH CAUSES.



**BS&B SAFETY SYSTEMS, L.L.C.**  
**BS&B SAFETY SYSTEMS LTD.**

BS&B Safety Systems, L.L.C. and BS&B Safety Systems Ltd. are here to assist you in providing a safe and efficient work place. For assistance on installation, audits, training or technical advice, please contact our Customer Service Department.

**BS&B Safety Systems, L.L.C.**

7455 East 46th Street  
Tulsa, OK 74145  
Telephone: 918-622-5950  
Facsimile: 918-665-3904  
www.bsbsystems.com

**BS&B Safety Systems Ltd.**

Raheen Business Park  
Raheen, Limerick, Ireland  
Telephone: +353 61 227022  
Facsimile: +353 61 227987  
www.bsb.ie

**ISO 9001 Quality System Certification**

